

APPLICATION:

PRODUCT NAME:
8" C/C BACKSPLASH FAUCET CV
W/DJ SWING SPOUT

JOB NAME:

SPECIAL CONFIGURATION
 CHECK BASE MODEL AND OPTIONS

QUANTITY:

ITEM NO.

MODEL:
 2283

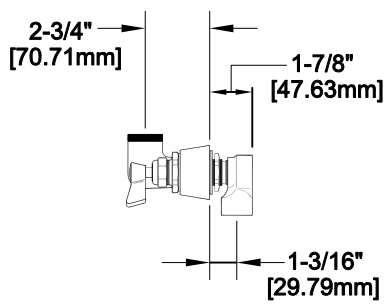
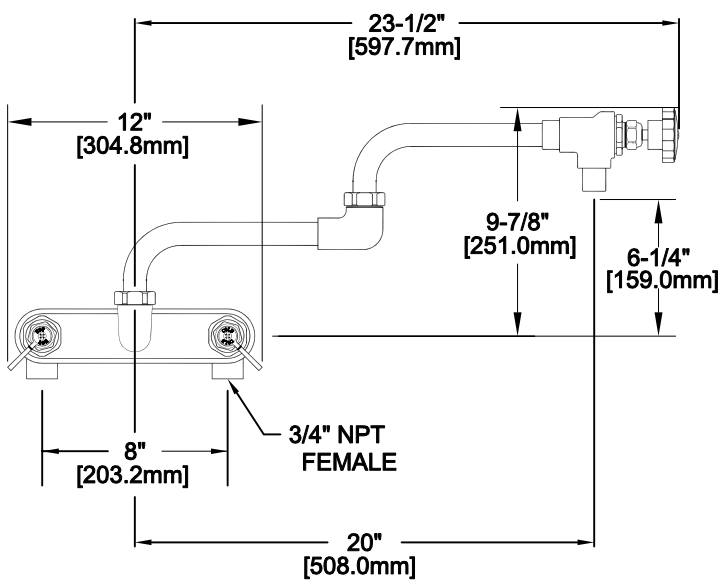

ROUGH-IN:

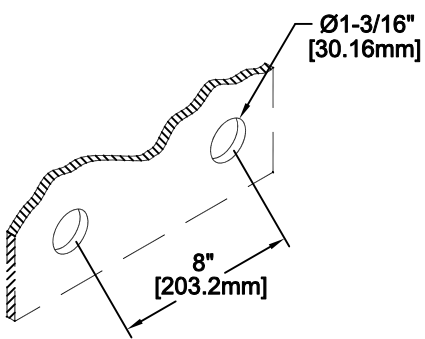

OPTIONS OR MODIFICATIONS:
 SUPPLY LINES (24" OR 36") CIRCLE LENGTH
 NIPPLES
 ELBOWS
 HANDLES (CROSS OR WRIST) CIRCLE STYLE
 VANDAL RESISTANT KIT
 OTHER _____

FEATURES

- * 8" DECK
- * INTERNAL SPRING LOADED CHECK VALVES
- * SWIVELLING SEAT DISKS
- * HOT SIDE STEM - LEFT HAND, COLD - RIGHT HAND
- * STAINLESS STEEL SEATS
- * STAINLESS STEEL SEAT SCREWS
- * STAINLESS STEEL HANDLE SCREWS
- * CLOSE ELBOWS
- * SHUT-OFF SPOUT

RECOMMENDED SETTINGS

- * 110°F AT 80 PSI

SYSTEM LIMITS

- * TEMP: 40°F MIN. TO 140°F MAX.
- * PRESSURE 200 PSI MAX. STATIC
- * 29 GPM @ 80 PSI

SHIPPING WEIGHT

- * 10.0 LBS